

**PHILIPS**

**SUPERM**  
*Mark II*

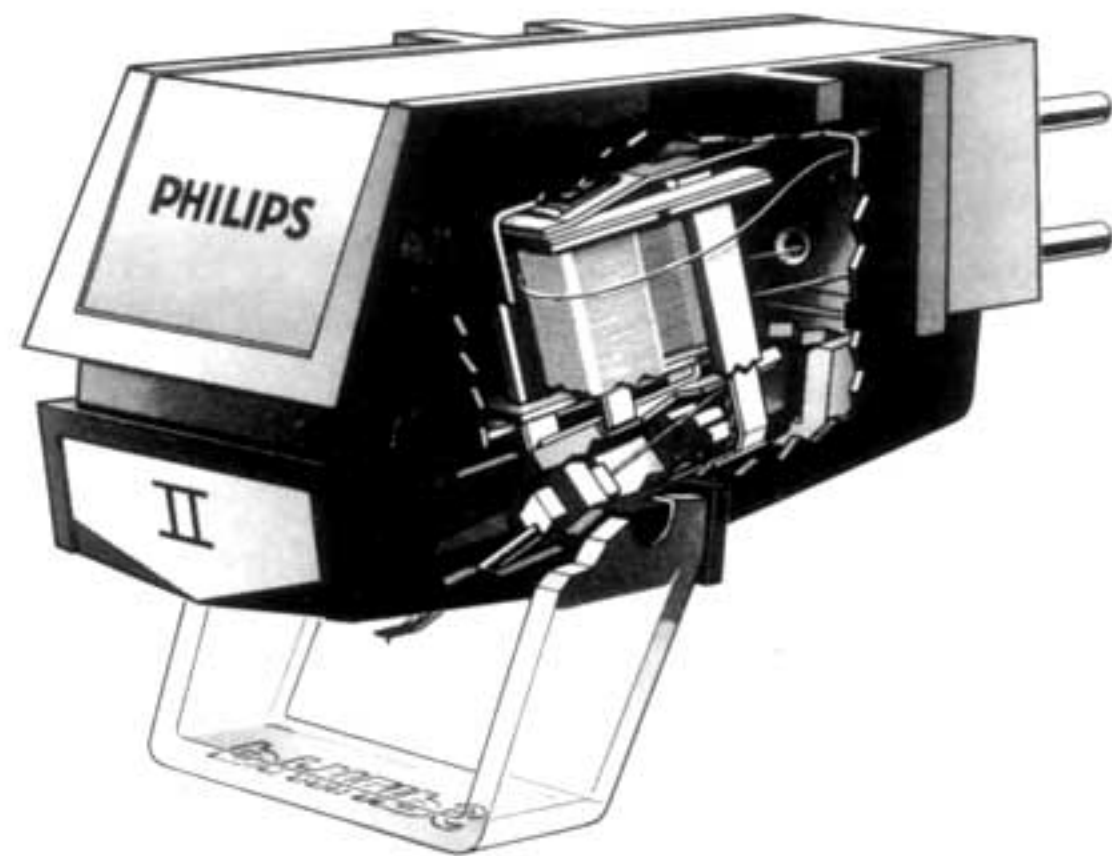

## **Introduction**

The heart of the SUPER M II High Fidelity pick-up cartridges GP 400 II, GP 401 II and GP 412 II is the tiny magnet of high-energy SUPER M magnet steel. The properties of this perfectly stable material permit an optimal flux density of the magnet of 8500 gauss, a remarkably high value resulting in a high sensitivity. Consequently a very favourable signal-to-noise ratio can be obtained with this cartridge.

The most advanced metallurgical techniques and the most modern elastomers enabled this cartridge to be made with extremely small and light components machined to micro-inch precision. The almost negligible

mass of the moving parts and their perfectly controlled mechanical properties and low dynamic mass, which are first conditions for good tracking at low stylus forces, achieve a response curve that extends from subsonic to ultrasonic with perfect regularity. Equally important is that the non-linear distortion has been brought down to the theoretical minimum.

The GP 400 II cartridge has a spherical diamond stylus with a radius of 15  $\mu\text{m}$  and the cartridges GP 401 II and GP 412 II are fitted with a bi-radial  $7 \times 18 \mu\text{m}$  diamond stylus. The shape of this stylus substantially reduces tracking distortion to a very low level, even of strong signals which have been recorded in the frequency range of maximum aural sensitivity. It also ensures contact

at the part of the record groove wall where imperfections are least likely to be present.

The GP 412 II, by virtue of its low tracking force of 0.75-1.5 gf, its high compliance and further perfections is undoubtedly the top performer of the three and as such distinguishes itself as one of the most remarkable achievements in cartridge design so far available.

For every SUPER M II High-Fidelity pick-up cartridge, the response curve (equalised according to the IEC/RIAA/NARTB standards) is measured by means of a precision pen recorder on laboratory standard records to an accuracy of better than  $\pm 0.3$  dB. Only when the actual curve is within the permitted close tolerances does the cartridge pass the final inspection.

## **Application**

SUPER M II cartridges should only be installed in tone arms especially designed for low tracking forces and having low friction bearings.

The recommended stylus forces for optimum results are listed under 'Technical Data'. Forces greater than the indicated 'maximum' should not be used.

## **Mounting**

First consult the directions for use of the record player or tone arm. SUPER M II cartridges have standard  $\frac{1}{2}$ " (12.7 mm) mounting centres.

The hardware for mounting purposes can be found under the velvet insert in the box.

*a. Philips HiFi record players*

Philips HiFi record players are supplied with a sliding carrier for mounting of SUPER MII cartridges. The cartridge has to be mounted on the smooth side of the carrier. The position of the cartridge on the carrier is determined by the notches in the edge of the slots for the nuts. Place the nuts in their notches and push the screws through the slots on both sides of the cartridge (Fig. 1). The length of the screws should be chosen so that they do not project above the edge of the carrier. Tighten the screws uniformly.

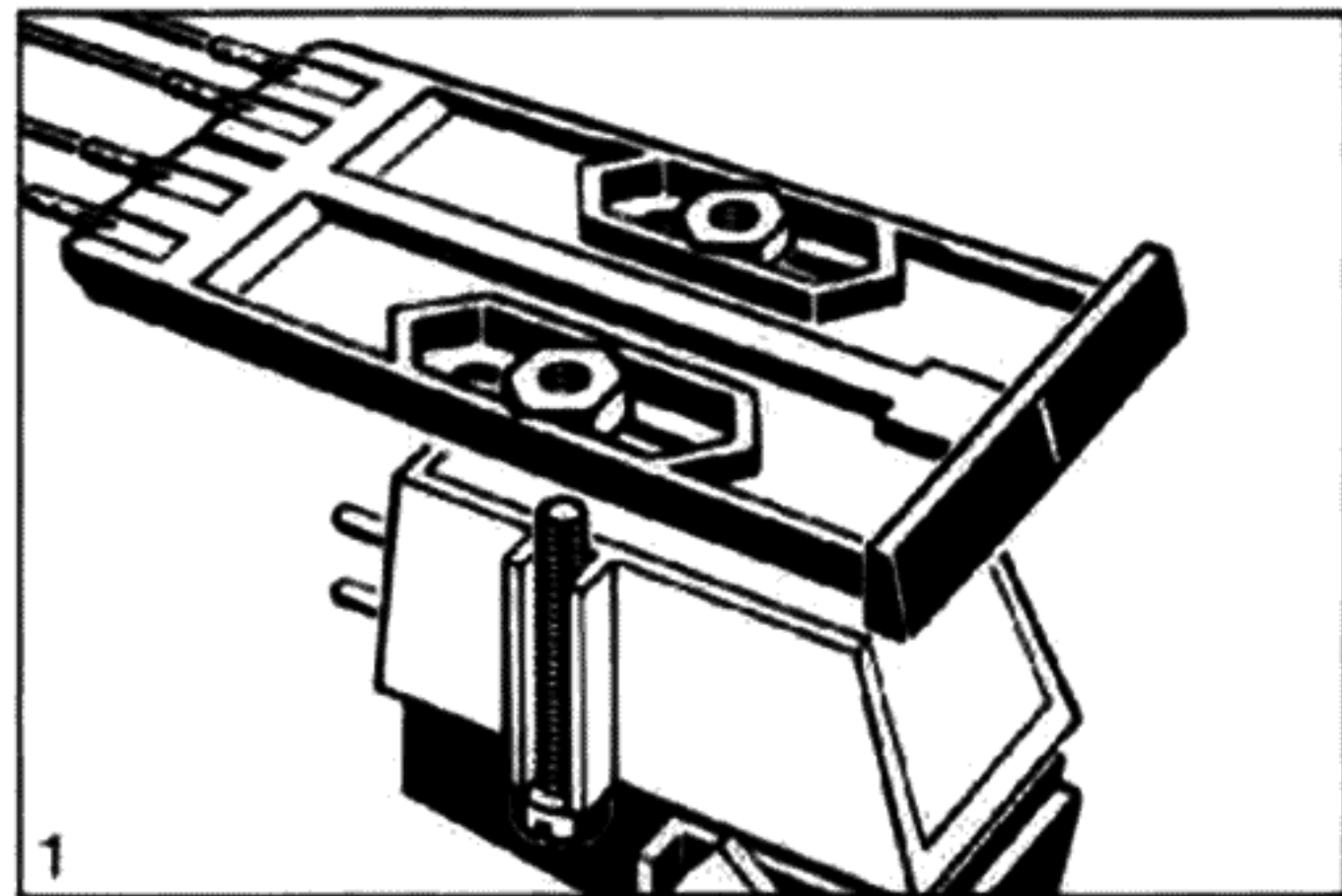

*b. Other record players and tone arms*

Mount the cartridge with two screws in the headshell or on the tone arm (Fig. 2).

Observe the paragraphs about overhang and height adjustment in the record player operating instructions.

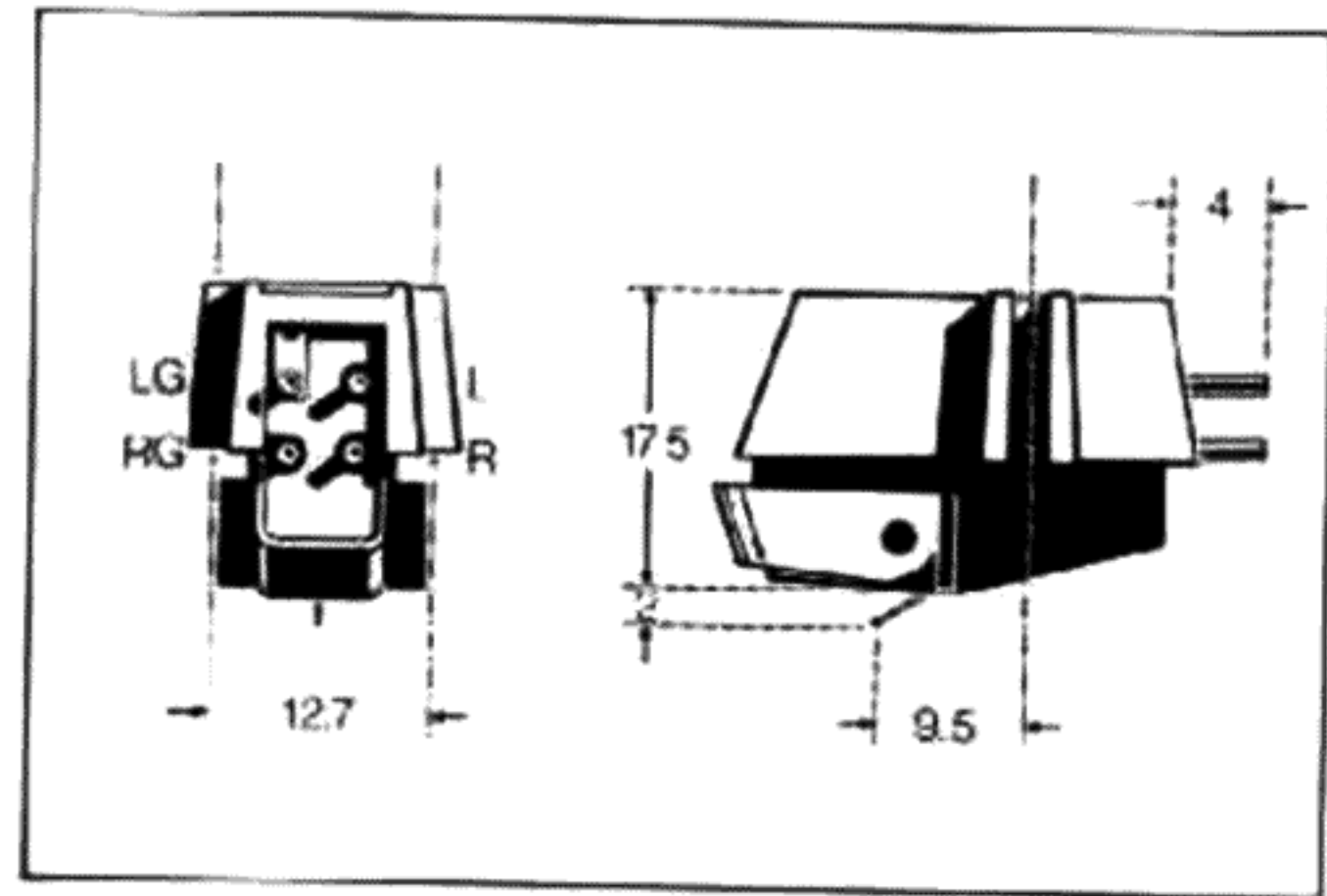
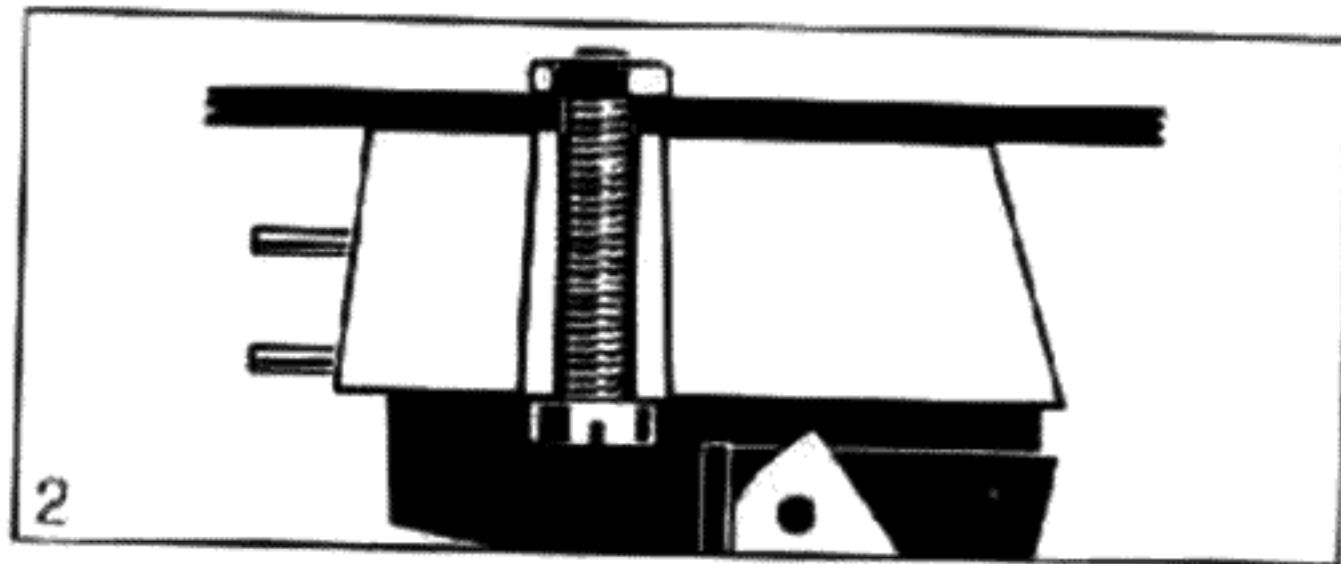

## Connections

### *a. Philips HiFi record players*

Connect the coloured leads on the carrier to the terminals on the cartridge as follows:

L (white) to L (left-hand channel)

R (red) to R (right-hand channel)

LG (blue) to LG (return left-hand channel)

RG (green) to RG (return right-hand channel)

Slide the carrier into the headshell.

### *b. Other record players and tone arms (Fig. 3)*

**Caution!** Do not make solder connections to the cartridge terminals but use, if necessary, the terminal jacks

provided to fix the signal and ground leads to the cartridge terminals. Do not solder these jacks to the leads when they are on the cartridge.

● 4 lead stereo connection: Connect the left-hand channel signal lead to terminal L and the left-hand channel shield or ground lead to terminal LG. Connect the right-hand channel signal lead to terminal R and the right-hand channel shield or ground lead to terminal RG.

● 3 lead stereo connection: Connect the left-hand channel signal lead to terminal L and the right-hand channel signal lead to terminal R. Connect the shield or ground lead to both terminal LG and terminal RG.

*Colour code according to IEC/EIA standards.*

- white - left-hand channel signal (L)
- red - right-hand channel signal (R)
- blue - left-hand channel return (LG)
- green - right-hand channel return (RG)

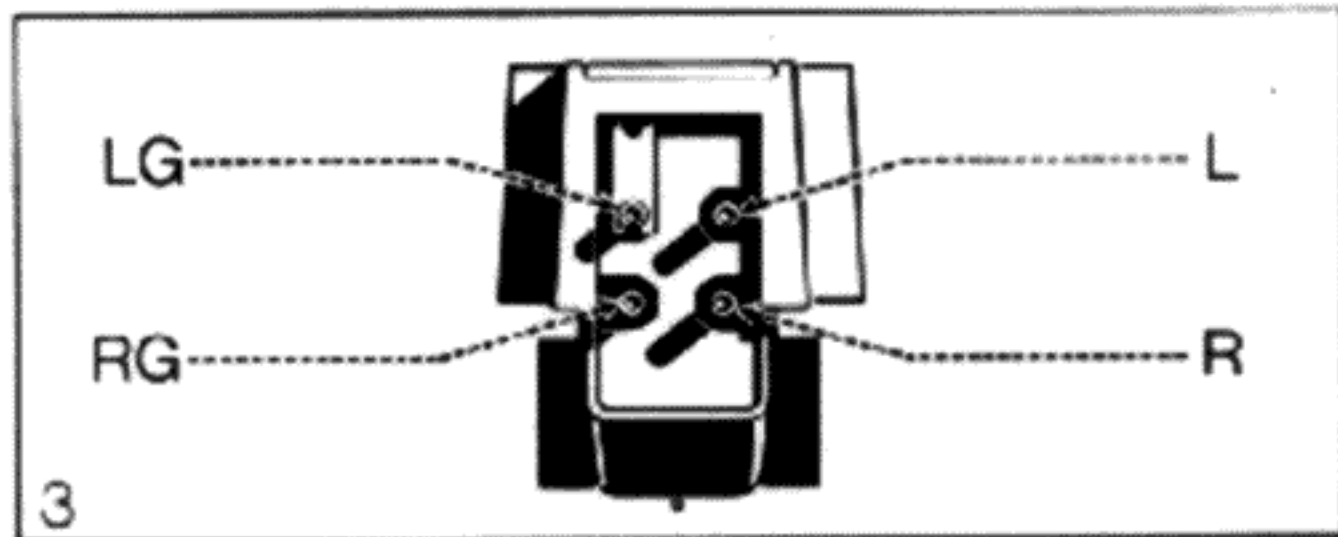

### **Replacement of the stylus unit**

Although the stylus is subject to very little wear it is recommended to have it checked by your dealer at regular intervals, e.g. twice a year.

To replace the stylus unit, hold the cartridge upside down in one hand and take hold of the stylus unit with the thumb and index finger of the other hand. Slide the stylus unit out of the cartridge, carefully and in a straight line (Fig. 4). The new stylus unit can now be slid into the cartridge, carefully and in a straight line.

*Note:* Be certain that any replacement stylus you buy bears the Philips wordmark on the stylus protector and the packing.



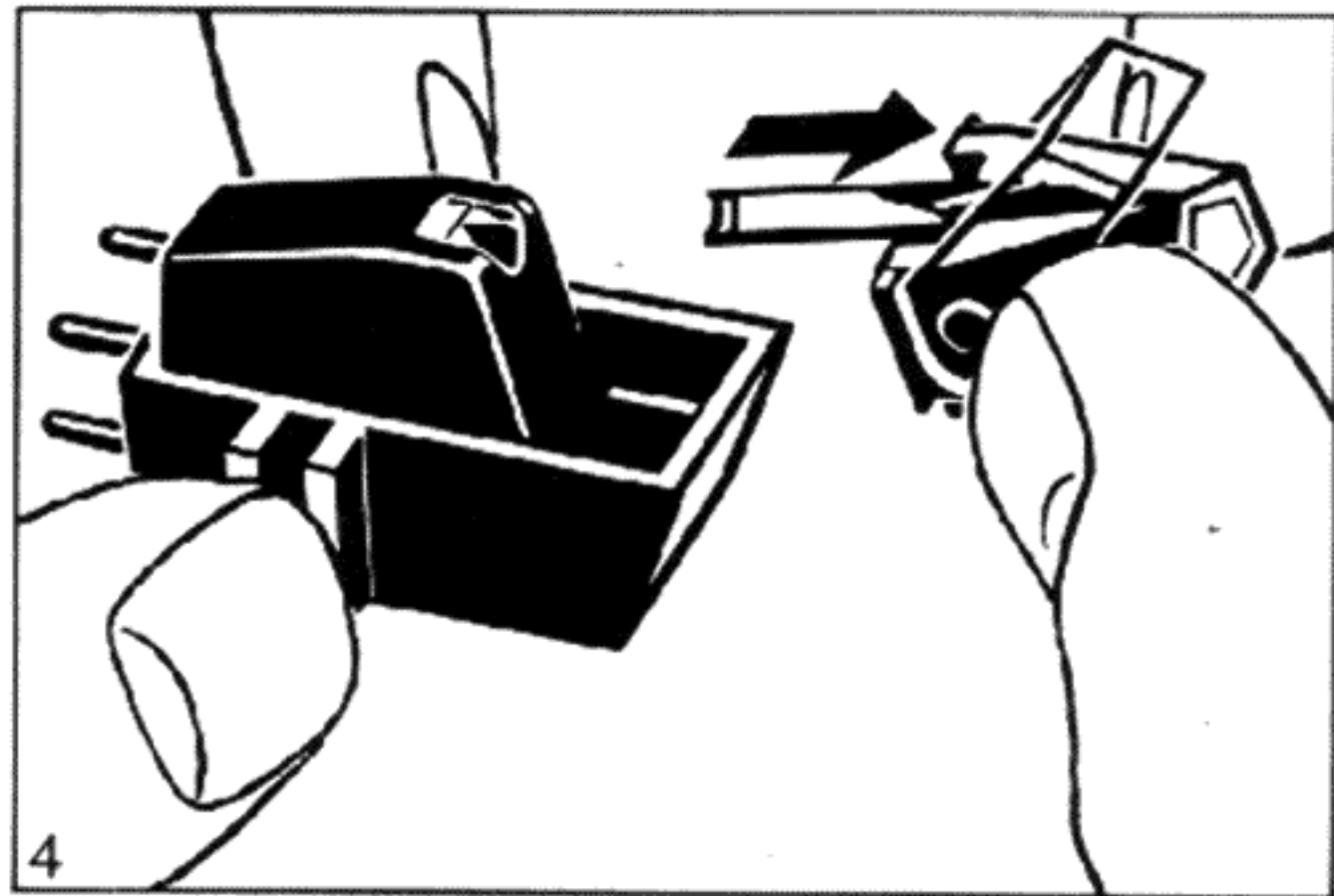

4

**GP 400 II**

stainless steel

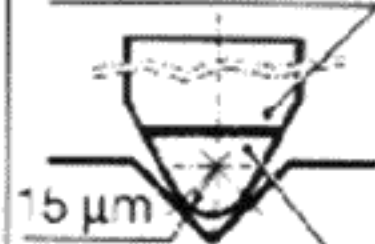

15  $\mu\text{m}$

diamond

stylus mass:  
0.2 mg  
spherical

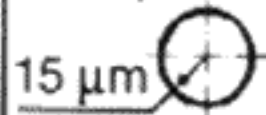

15  $\mu\text{m}$

**GP 401 II**

stainless steel

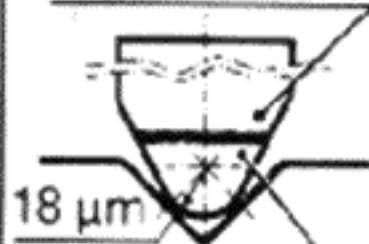

18  $\mu\text{m}$

diamond

stylus mass:  
0.2 mg  
elliptical

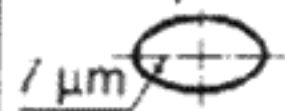

7  $\mu\text{m}$

**GP 412 II**

titanium  
or sapphire



18  $\mu\text{m}$

diamond

stylus mass:  
0.1 mg  
elliptical

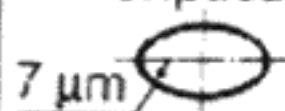

7  $\mu\text{m}$

**Technical Data**

	<b>GP 400 II</b>	<b>GP 401 II</b>	<b>GP 412 II</b>
Net weight.....	6 g	6 g	6 g
Mounting distance.....	Retma 1/2"	Retma 1/2"	Retma 1/2"
Stylus (diamond).....	15 $\mu$ m	7 x 18 $\mu$ m	7 x 18 $\mu$ m
Stylus mass.....	0.2 mg	0.2 mg	0.1 mg
Sensitivity.....	1.3 mV/cm/sec	1.3 mV/cm/sec	1.5 mV/cm/sec
Output asymmetry at 1 kHz.....	< 2 dB	< 2 dB	< 1 dB
Channel separation at 1 kHz.....	> 29 dB	> 29 dB	> 30 dB
Compliance lateral.....	> 20 mm/N	> 20 mm/N	> 30 mm/N
Compliance vertical.....	> 16 mm/N	> 16 mm/N	> 20 mm/N
Stylus force.....	1.5 ... 3 gf	1.5 ... 2.5 gf	0.75 ... 1.5 gf
FIM distortion (at recommended stylus force).....	< 0.9% (2 gf)	< 0.8% (1.7 gf)	< 0.7% (1.2 gf)
Frequency response $\pm$ 2 dB.....	20-20,000 Hz	20-20,000 Hz	20-25,000 Hz
Resistance per channel.....	950 $\Omega$	950 $\Omega$	950 $\Omega$
Inductance per channel.....	540 mH	540 mH	540 mH
Recommended cable capacitance.....	< 250 pF	< 250 pF	< 250 pF
Recommended load impedance.....	> 47 k $\Omega$	> 47 k $\Omega$	> 47 k $\Omega$
Codenummer of stylus unit.....	4822 251 30048	4822 251 30049	4822 251 30051

Brüel & Kjær

Measuring Obj:

*GP 412 II*

Rec. No.:

Date:

Sign.:

QP 0124

Potentiometer Range: \_\_\_\_\_ dB Rectifier: \_\_\_\_\_ Lower Lim. Freq.: \_\_\_\_\_ Hz Wr. Speed: \_\_\_\_\_ mm/sec. Paper Speed: \_\_\_\_\_ mm/sec.

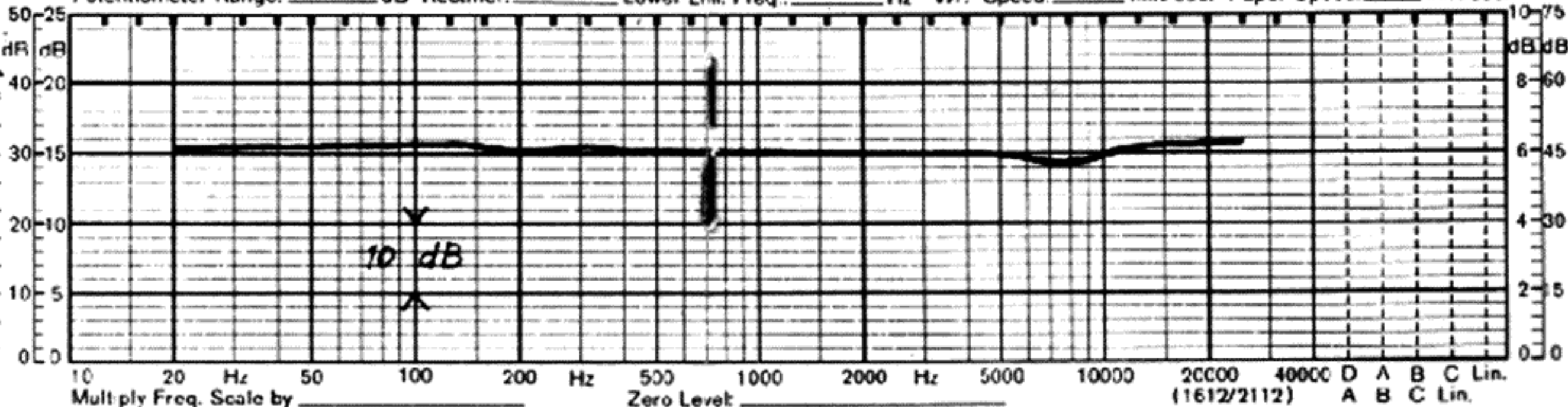

Typical frequency response

Réponse en fréquence typique

3112 116 01102

277/2